



XIII
INTERNATIONAL
WINTER ROAD
CONGRESS

QUÉBEC, FEBRUARY 8 TO 11, 2010



Québec 

SUSTAINABLE WINTER SERVICE FOR ROAD USERS

Feasibility study on the suitability of automated acetic acid cryoprotectant dispersion systems on urban expressways

Hisatoshi Murakami

Hanshin Expressway Engineering Co.,Ltd

hisatoshi-murakami@hex-eng.co.jp



阪神高速技術



Introduction

- The oldest section of the Hanshin Expressway was opened to traffic in 1964, and the total length of 242.0km is in service at present.
- The Hanshin Expressway is toll road.

Overview of the Hanshin Expressway
(around Minato-machi area)



Location of 242.0km Network

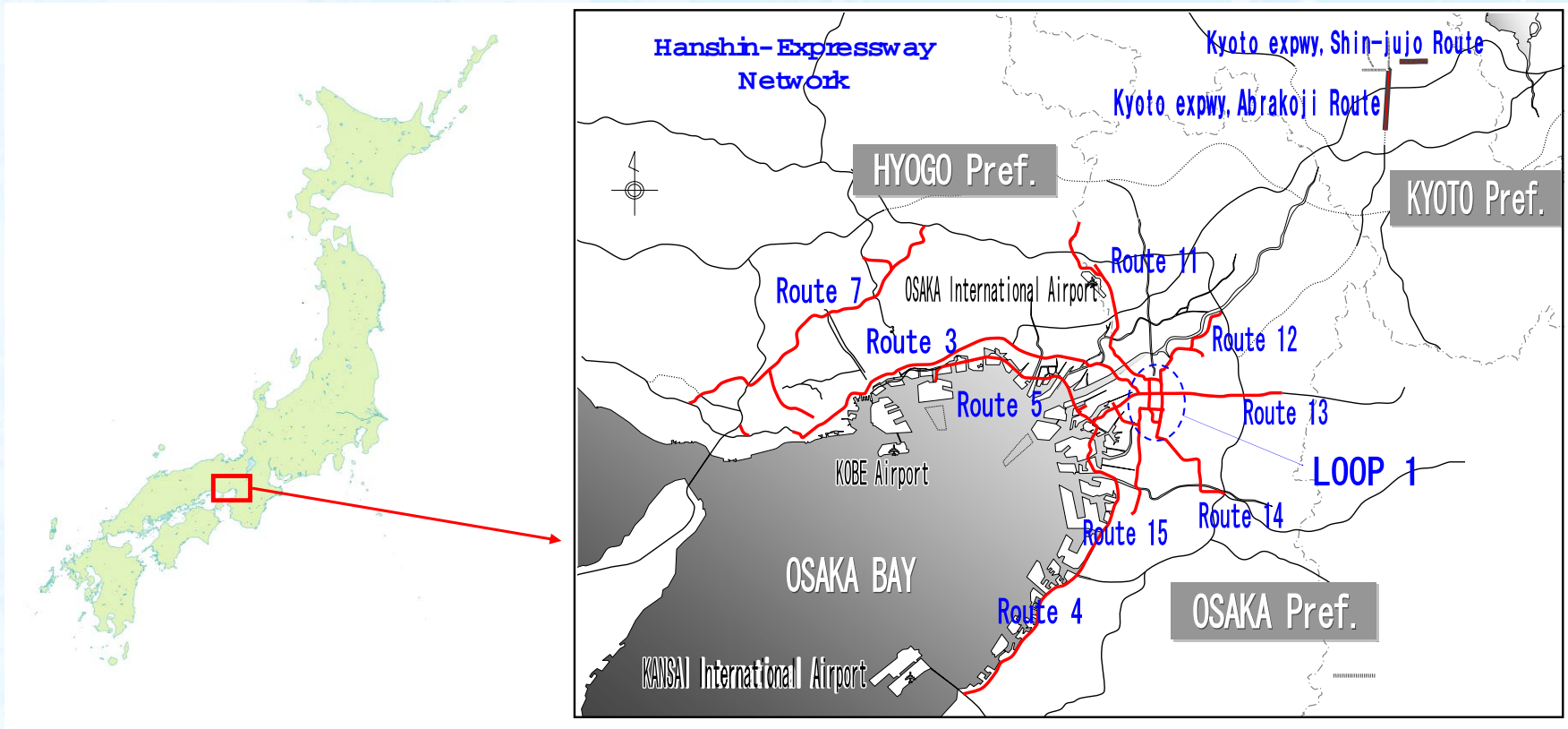

Location of Hanshin Expressway

In-service Length 242.0km

Viaducts in highly urbanized area go along the river, over the city street, and...

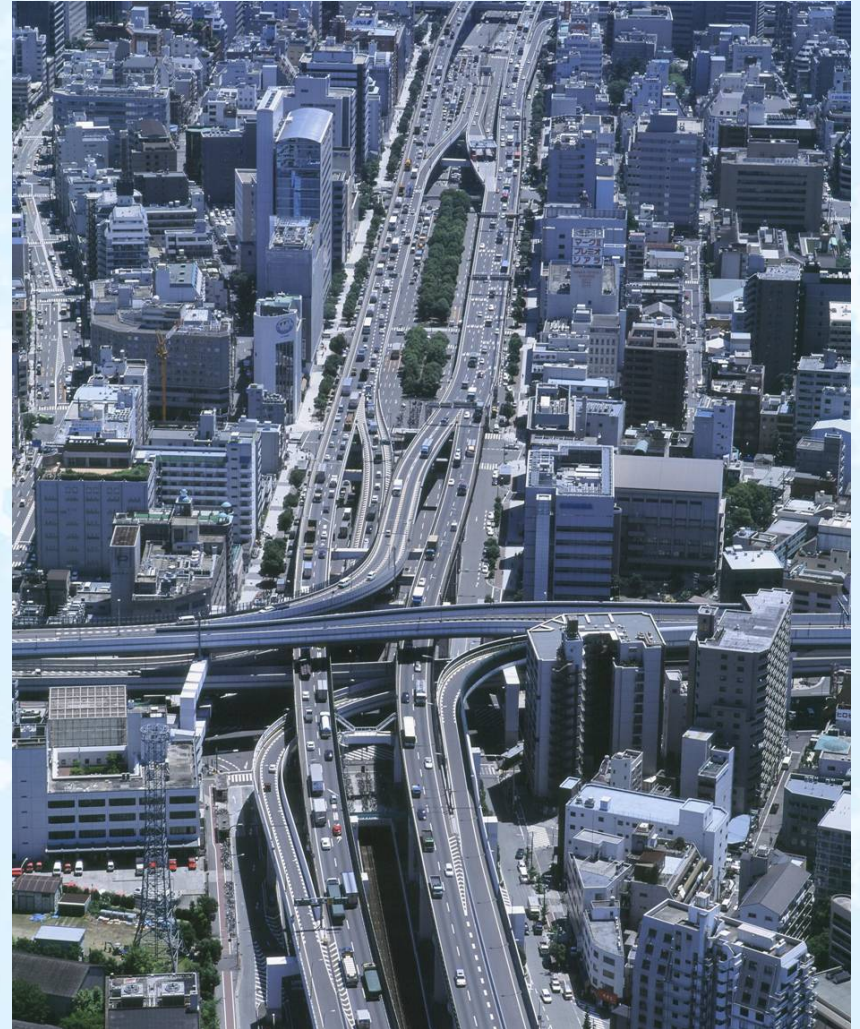

Long-spanned Bridges on Osaka Bay Area



The winter season road surface management of the Hanshin Expressway. (prevent surface icing)



The winter season road surface management of the Hanshin Expressway. (The snow removing after the snowfall)



The consumption of sodium chloride for prevent surface icing.

F Y	Osaka area	Kobe area	Total (tons)
2007	1,557	1,430	2,987
2008	866	1,045	1,911

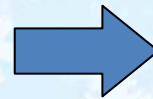

Not only rainfalls but also sodium chloride.....

For the purpose of the study

De-icing agents

- **CHLORIDE-BASED AGENTS**

been in use for many years, but encouraging corrosion of road way structures.

- **ACETIC BASED AGENTS**

environmentally-friendly, but, tend to be costly.



Feasibility study on the suitability of automated acetic acid cryoprotectant dispersion system on urban expressways.

CAMAG : a liquid agent based on potassium acetate with glycerin additive.

Main components and performance of CAMAG.

CAMAG

Potassium acetate: cryoprotectant agent

Glycerin: extend performance, boost water retention improve dispersion

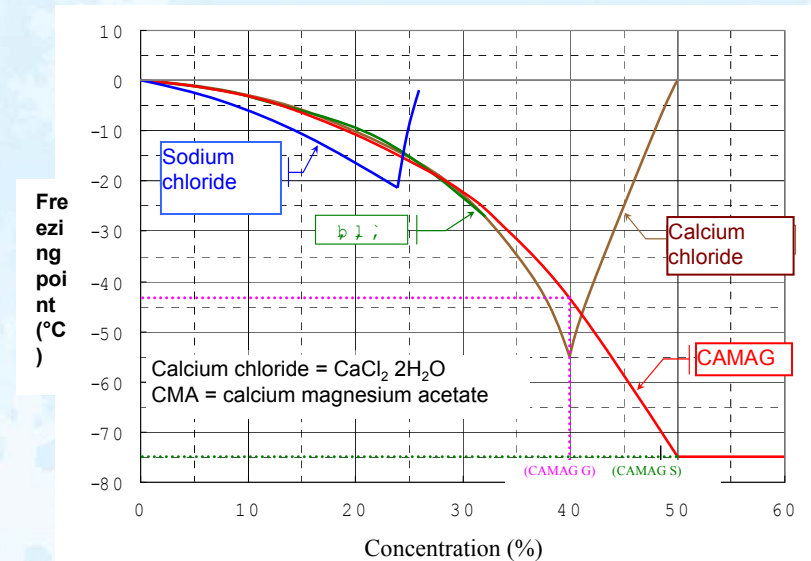

- Freezing point -75□.
- Viscosity increases tire drag.
- No adverse environmental impact on plants and other ecosystems.
- Negligible corrosive effect on metal components of vehicles, also roadway structures.
- Biological decomposition

Potassium acetate $\text{CH}_3\text{COOK} \rightarrow \text{H}_2\text{O}, \text{CO}_2, \text{K}$

Glycerin $\text{C}_3\text{H}_5(\text{OH})_3 \rightarrow \text{H}_2\text{O}, \text{CO}_2$

Usage in conjunction with automated dispersion systems

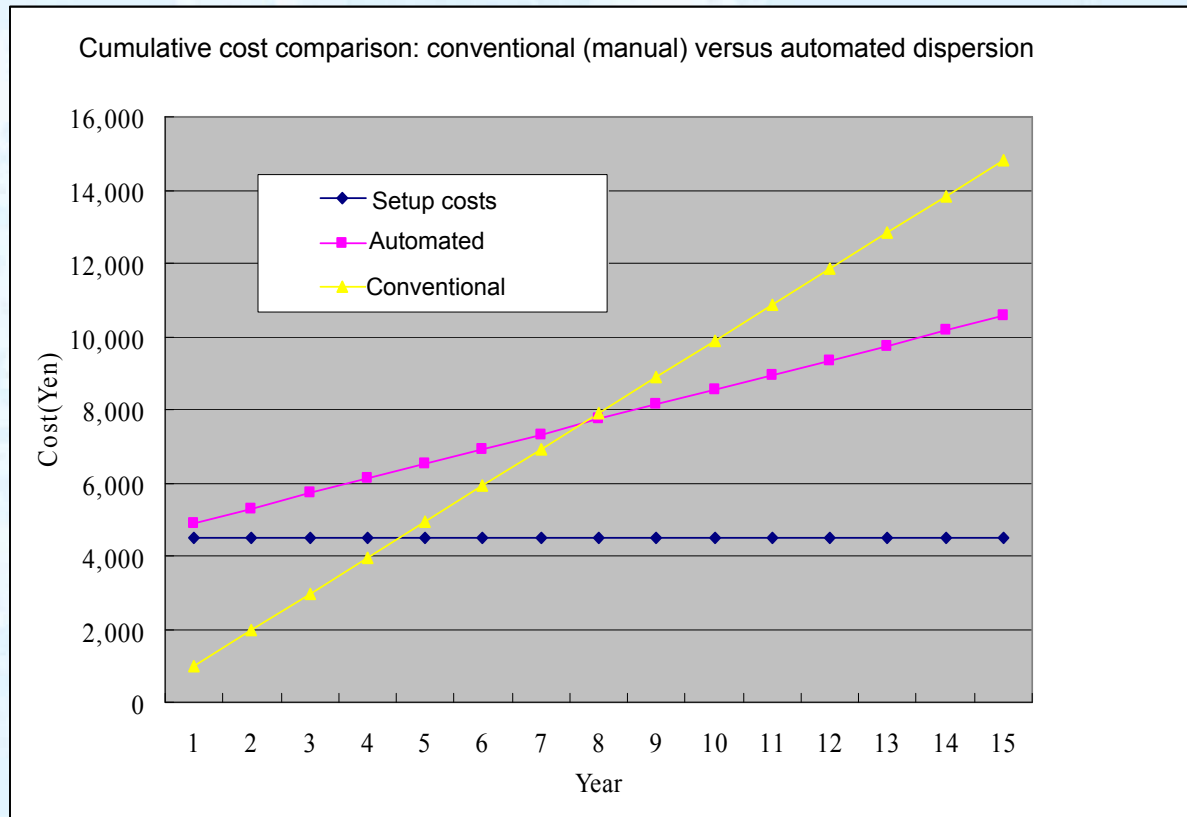

Assuming setup = \45.0 million,
equipment maintenance = \4.04 million,
Conventional de-icing expenses = \9.87 million

Automated dispersion system

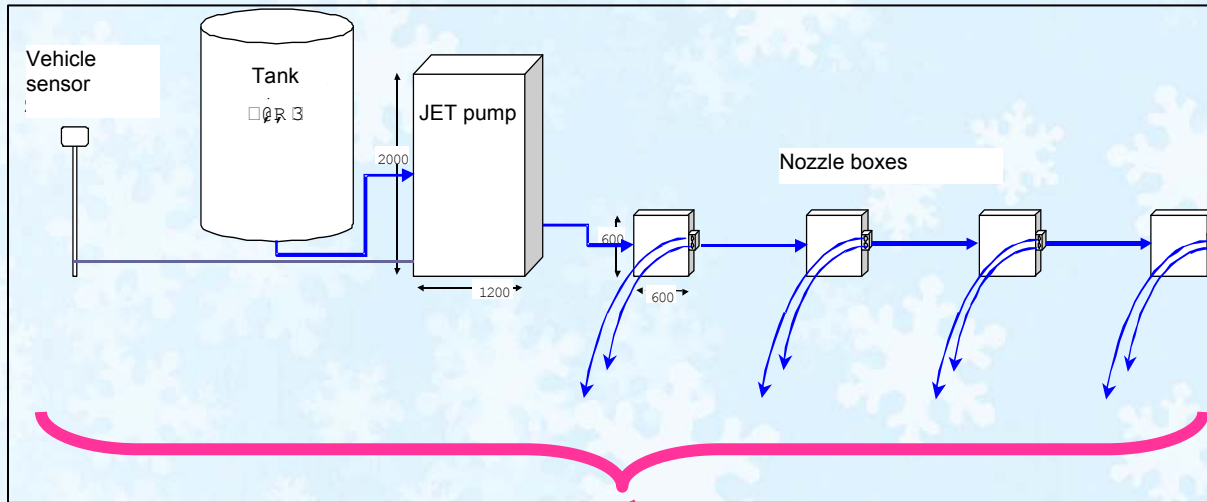

← Higher temperature (Bay side)

→ Lower temperature (Mountain side)

System operation controller and tank



Controller



Storage tank

System operation independent nozzles



System operation

Vehicle sensor



Inbound lane



Outbound lane

System operation temperature sensor

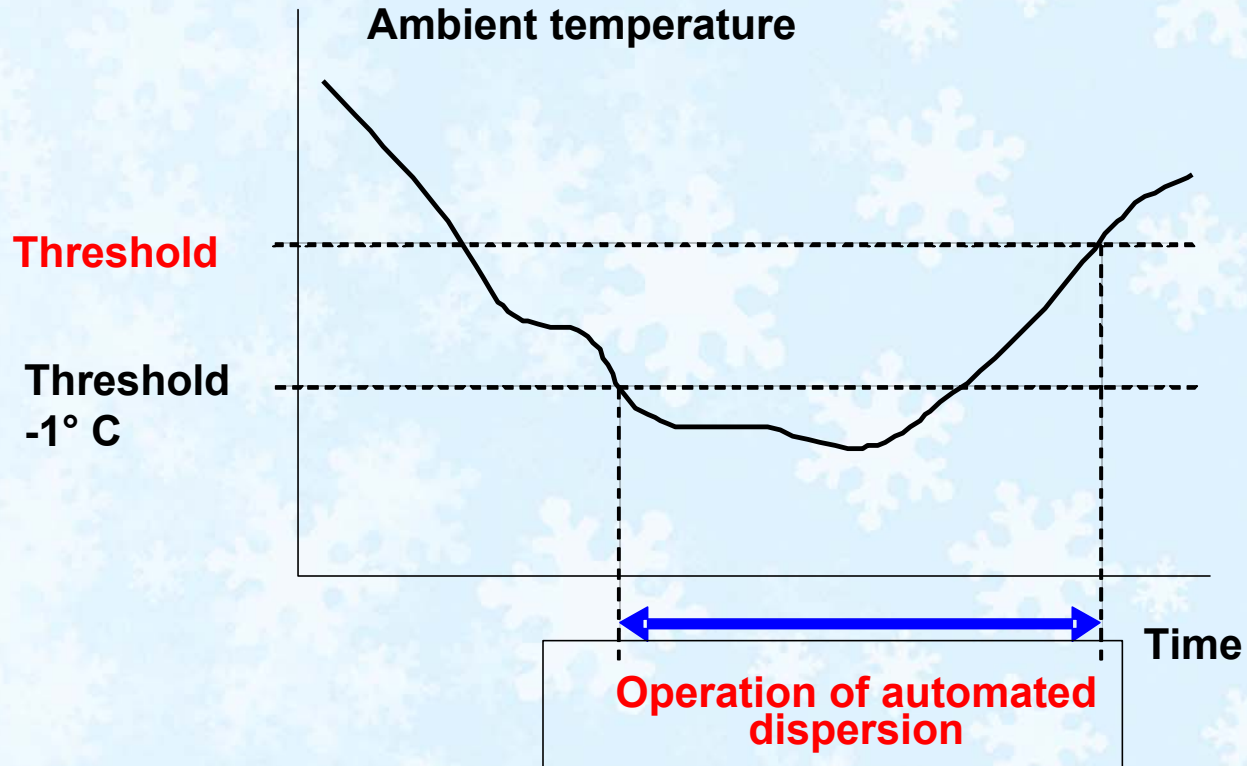

Conclusion and future considerations

Benefits of the automated dispersion system

- 1) The automated system operated faultlessly and produced the required outcome.
- 2) Automated timing linked to temperature sensor.
- 3) Cost savings
- 4) Support for remote control functionality.
- 5) Installation points on the Hanshin Expressway
- 6) Snow melting performance

Thank you very much.

Merci beaucoup.